

NS/EK

U. S. NAVAL TECHNICAL MISSION TO JAPAN
CARE OF FLEET POST OFFICE
SAN FRANCISCO, CALIFORNIA

10 February 1946

RESTRICTED

From: Chief, Naval Technical Mission to Japan.

To : Chief of Naval Operations.

Subject: Target Report - Japanese Shipboard Rocket Launchers.

Reference: (a)"Intelligence Targets Japan" (DNI) of 4 Sept. 1945.

1. Subject report, covering Target O-50(N) of Fascicle O-1 of reference (a), is submitted herewith.

2. The investigation of the target and the target report were accomplished by Comdr. (E) A. J. Stewart, RN.



C. G. GRIMES
Captain, USN

RESTRICTED

INDEX NO. O-50(N)

**JAPANESE SHIPBOARD
ROCKET LAUNCHERS**

**"INTELLIGENCE TARGETS JAPAN" (DNI) OF 4 SEPT. 1945
FASCICLE O-1, TARGET O-50(N)**

FEBRUARY 1946

U.S. NAVAL TECHNICAL MISSION TO JAPAN

SUMMARY

ORDNANCE TARGETS

JAPANESE SHIPBOARD ROCKET LAUNCHERS

Only one of the **rocket** launchers used by the Japanese Navy was of any interest. It was a triple 25mm machine gun mount, remotely controlled by a Ward Leonard System, which had been modified in July 1944 to fire twenty-eight 12cm rockets, weighing 49½ pounds each, to a range of approximately 3260 feet vertically and 1640 yards on the surface.

NTJ-L-0-50(N)

TABLE OF CONTENTS

Summary.....Page 1
List of Illustrations.....Page 3
References.....Page 4
Introduction.....Page 5
The Report.....Page 7

LIST OF ILLUSTRATIONS

DIAGRAMATIC SKETCHES OF 12cm, 28 BARREL ROCKET LAUNCHER

Figure 1. General Arrangement.....Page 8
Figure 2. Training and Elevating Electrical Circuits.....Page 9
Figure 3. Rocket in Firing Position.....Page 10
Figure 4. Firing Circuit.....Page 11

REFERENCES

Location of Target:

Kure Navy Yard.

Aircraft carrier KATSURAGI.

Japanese Personnel Interviewed:

Captain DAKE, Navy Technical Department, Navy Ministry, TOKYO.

Mr. OTANI and Mr. KOGA, Ordnance Department Kure Navy Yard.

Pertinent Reports of Other Intelligence Agencies:

Report No. 113 of the Ordnance Intelligence Section of the U. S. Army 5250th Technical Intelligence Company.

INTRODUCTION

The object of this investigation was to obtain information on rocket launchers of interest used by the Japanese Navy. Officers in the Ordnance Department at Kure Navy Yard and in the Navy Technical Department at TOKYO were interrogated. Launchers were inspected at KURE.

THE REPORT

Until 1944, only the crudest trough-like rocket launchers were used by the Japanese Navy. In June of that year orders were received to design a multiple rocket launcher suitable for shipboard use. One month was allowed for designing and producing the first model. In order to save time, the 25mm triple machine gun mount already in use (remotely controlled by a Ward Leonard System with a French-type L.P.R. simple course and speed sight) was modified for this purpose.

Twenty-eight barrels were fitted to this launcher. It was designed to fire 12cm rockets. Only the following alterations to the machine gun mounts were necessary:

- (1) A completely new cradle was fitted.
- (2) Thin steel cabinets were fitted on either side of the mount to protect the crew from flame.
- (3) The firing switch was changed to a rotary switch, to allow the rockets to be fired in a ripple.

The principal characteristics of the new launcher were as follows:

Length of "barrel".....	51.2 in
Diameter of rocket.....	4.73 in
Weight of rocket.....	49½ lbs
Length of rocket.....	28.76 in
Weight of explosive.....	0.44 lbs
Weight of propellant.....	7.48 lbs
Fuze (time).....	5.5 to 8.5 sec. delay
Firing mechanism.....	electric
Rate of fire.....	28 rockets in 10 sec
Combustion time of propellant.....	1.6 sec
Range, vertical.....	3280 feet
Range, surface.....	1640 yards
Limits of elevation.....	5° to +80°
Elevating speed (maximum).....	18°/sec (by power)
(One turn of handwheel.....)	3° of elevation)
Training speed (maximum).....	22°/sec (by power)
(One turn of handwheel.....)	3° or train)
Weight of elevating parts.....	1320 lbs
Weight of training parts.....	1720 lbs
Weight of base plate, etc.....	420 lbs
Total weight.....	3460 lbs

Four of these launchers with their directors have been shipped to the United States for examination. The director and its remote control system are described in NavTechJap Report, "Japanese Fire Control" (Index No. O-29). The 25mm triple machine gun mount is described in Enclosure (C) of NavTechJap Report, "Japanese Naval Guns and Mounts, Article 2-AA Machine Guns and Mounts" (Index No. O-47(N)-2). The general arrangement of the launcher and director is shown in Figures 1 to 4 of this report.

No other launchers of interest were used by the Japanese Navy.

SKETCH 1

TARGET 0-50

12 cm 28 BARREL ROCKET LAUNCHER

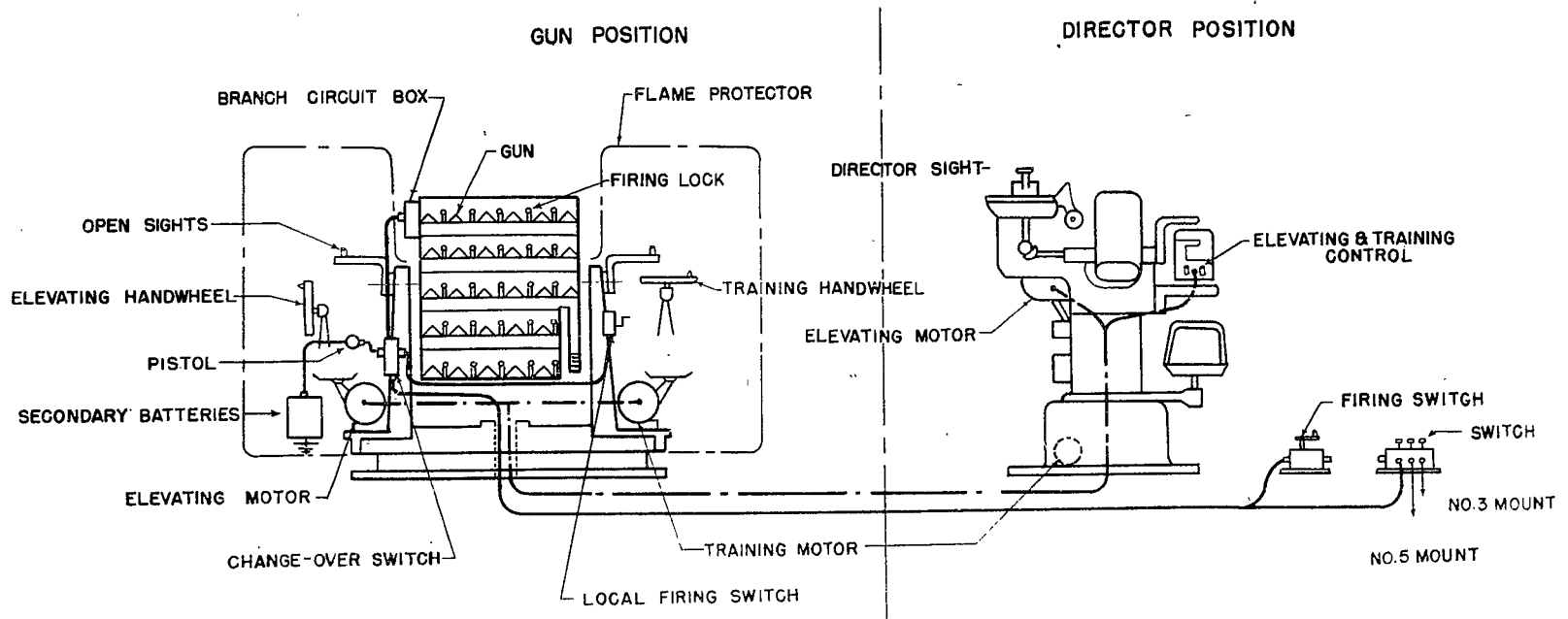
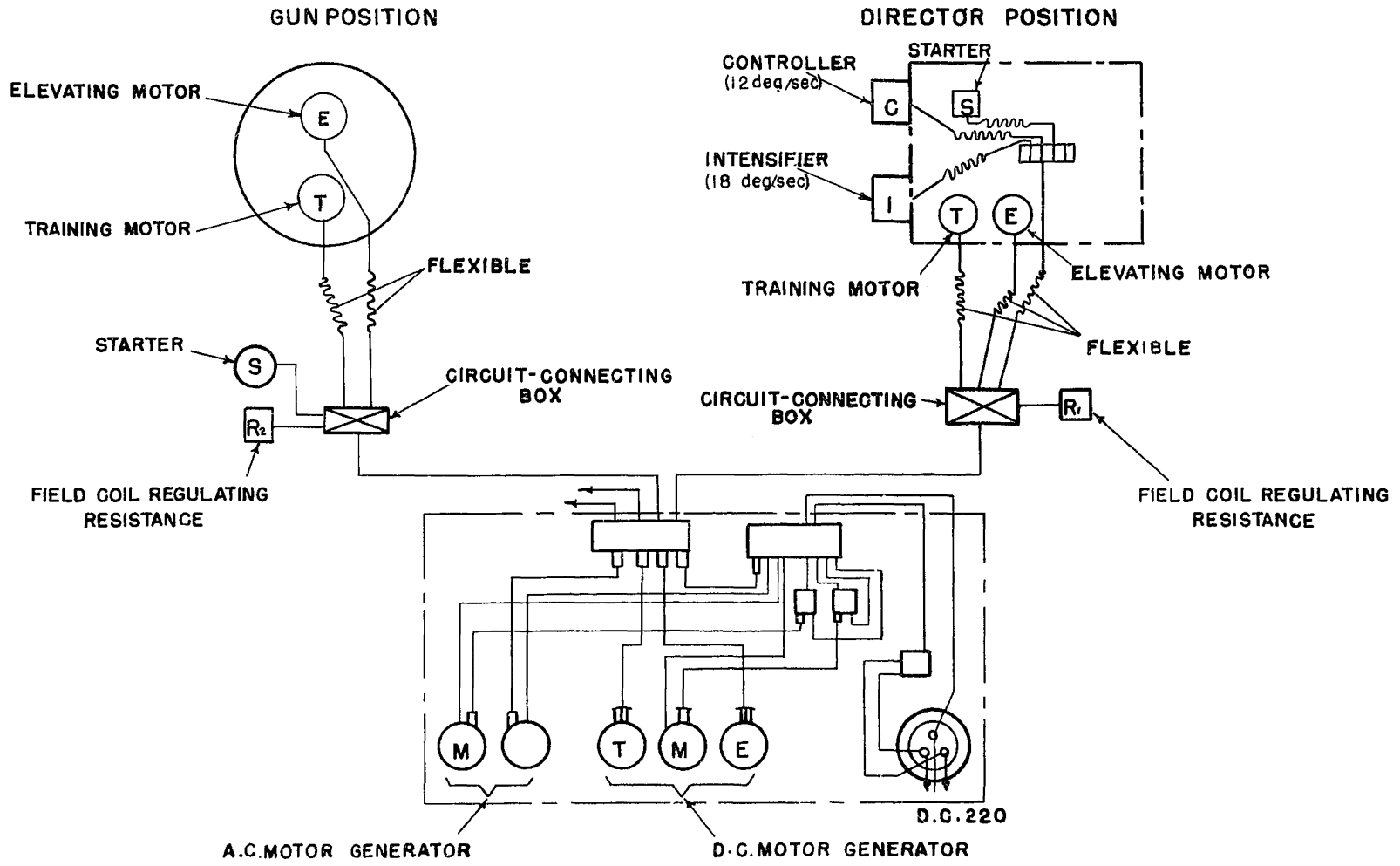

Figure 1
12 cm 28 BARREL ROCKET LAUNCHER - GENERAL ARRANGEMENT

8



6

1.5m 2.8 CALIBER ROCKET LAUNCHER - TRAINING AND ELEVATING ELECTRICAL CIRCUITS

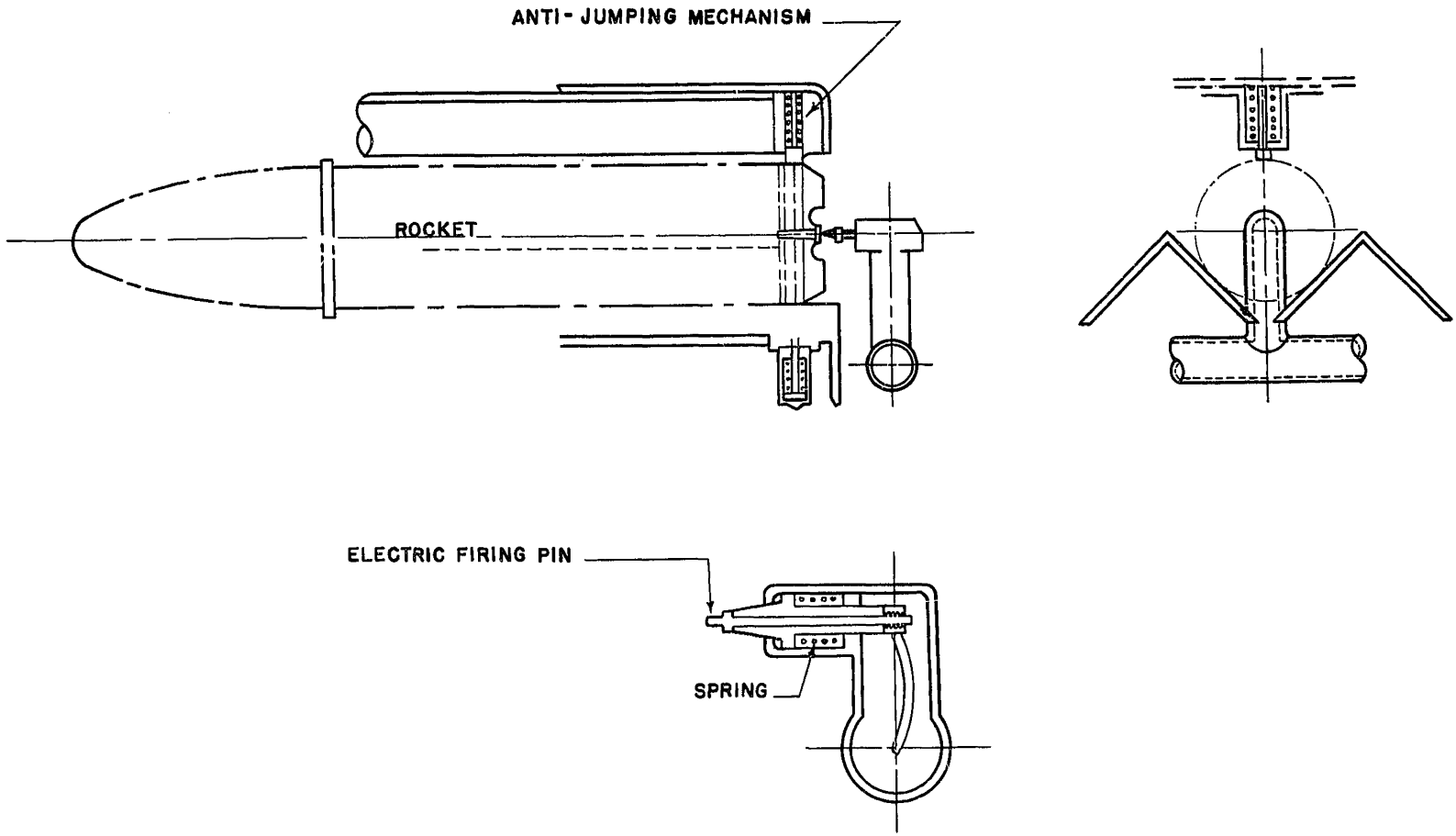

Figure 3
12cm 28 BARRETT ROCKET LAUNCHER - ROCKET IN FIRING POSITION

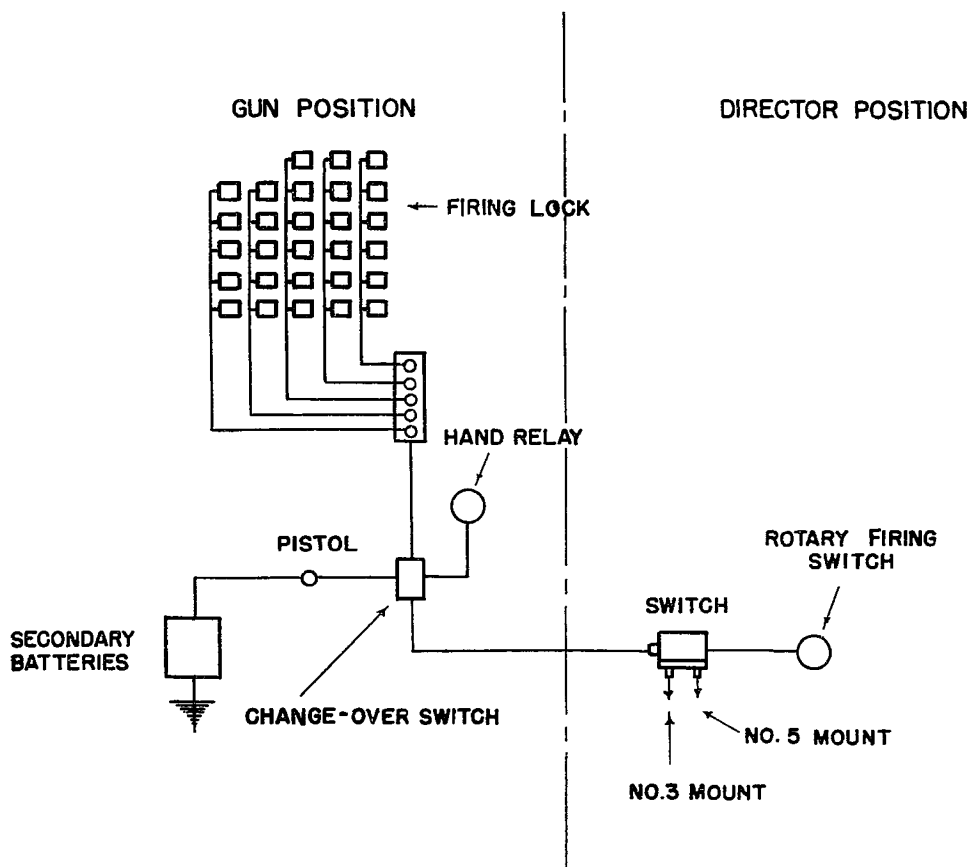

Figure 4
12cm 28 BARRREL ROCKET LAUNCHER FIRING CIRCUIT